

Building Digital Manufacturing Standards for an AM-supported Supply Chain

Digital Manufacturing
Building a Resilient Supply Chain

Paul Witherell, PhD
National Institute of Standards and Technology
April 21, 2023

- Introduction to NIST
- Digitalization in Manufacturing
- Exploiting Digitalization in the AM Supply Chain
- Developing Data-based Standards

To promote U.S. innovation and industrial competitiveness by advancing measurement science, standards, and technology in ways that enhance economic security and improve our quality of life

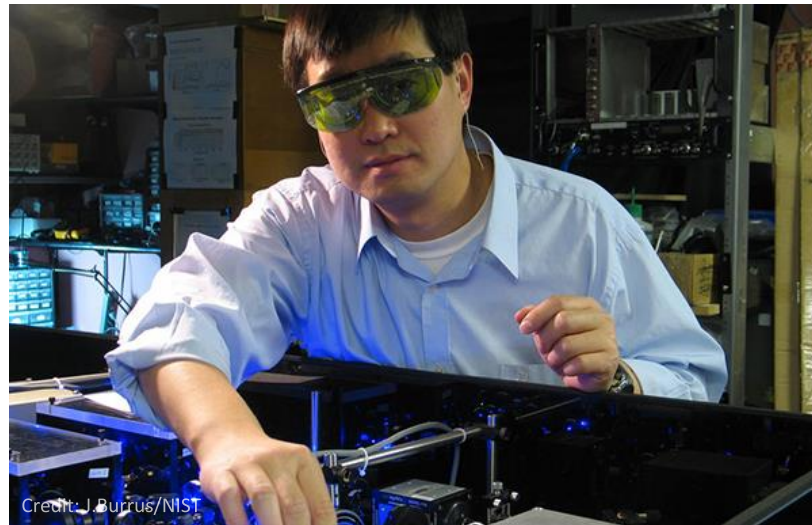

NIST AT A GLANCE

Industry's National Laboratory



3,400+
FEDERAL
EMPLOYEES



5
NOBEL PRIZES



2 CAMPUSES
GAITHERSBURG, MD [HQ]
BOULDER, CO



2,700+
ASSOCIATES



10
COLLABORATIVE
INSTITUTES



Thousands
BUSINESSES USING
NIST FACILITIES



ManufacturingUSA®

1
NATL OFFICE FOR 16
MANUFACTURING
INSTITUTES



51
MANUFACTURING
EXTENSION
PARTNERSHIP CENTERS



U.S. BALDRIGE
PERFORMANCE
EXCELLENCE PROGRAM

Additive Manufacturing at NIST

- Multiple Lab effort

- Engineering Lab
- Materials Measurement Lab
- Physical Measurement Lab
- Information Technology Lab
- NIST Center for Neutron Research

- Multiple Technologies

- Metals
- Polymers
- Concrete

Activities Include

- Workshops
- Roadmaps
- Standards Development
- Measurement Technology Development

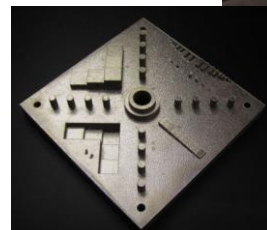
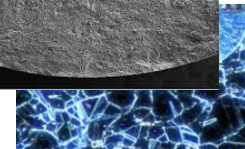
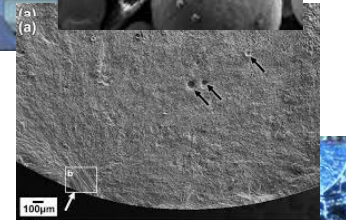
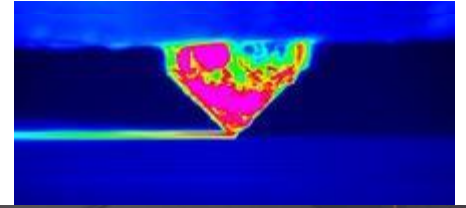

NIST Dedicated AM Facilities

Additive Manufacturing Research Center

- Powder Bed Fusion
 - EOS M270, EOS M290
- Directed Energy Deposition
 - Optomec LENS MR7
- Binder Jetting
 - ExOne

Powder characterization laboratory

- Dynamic imaging for PSD
- Laser flash for thermal properties
- Rheometer and powder spreading test platform

Post-processing and testing facilities

- High temperature heat treatment furnace, EDM
- XCT, White light interferometry, focus variation microscopy, SEM, XRD

New In Process capabilities coming...

- In Situ monitoring with Cornell High Energy Synchrotron Source
- New test bed developed for in situ measurements

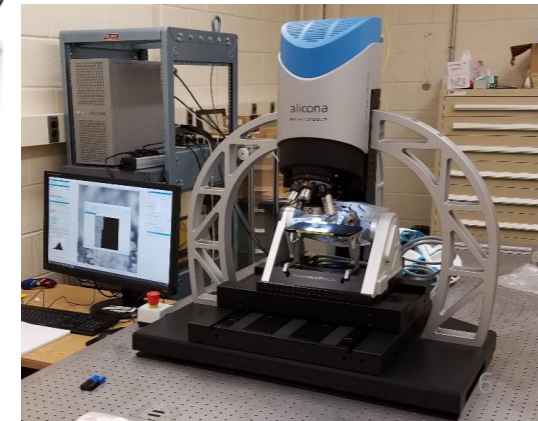

Digitalization in Manufacturing



Leveraging the Digital Nature of Advanced Manufacturing

- Current “state-of-the-art” most often benefits from increased digitalization
- Advanced manufacturing processes often driven by strong digital component
- The digital, piecewise nature of many of these processes lend themselves well to the digital twin concept

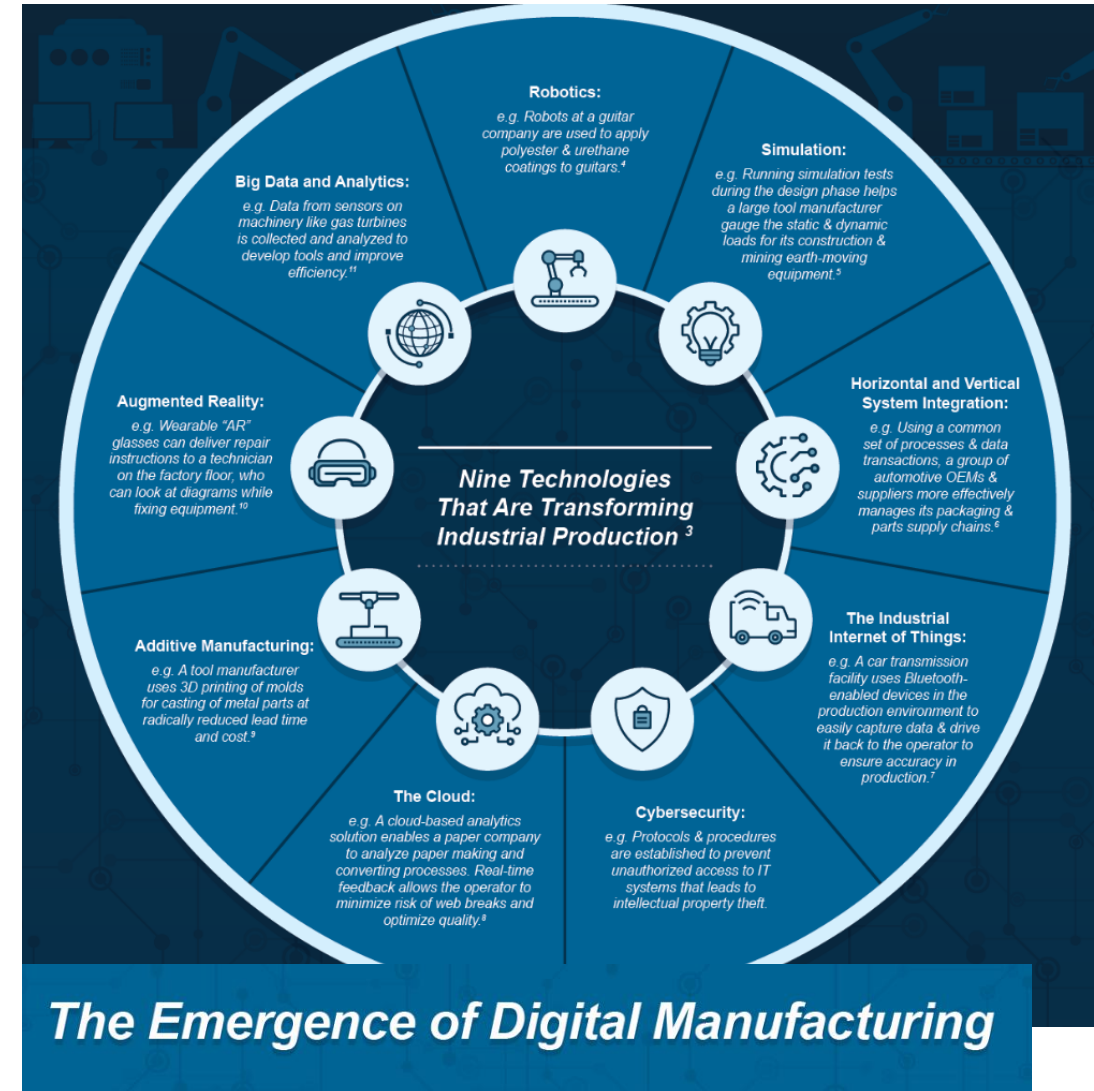

Foundation for a The Digital Twin

“a digital informational construct of a physical system as an entity on its own”
-Grieves and Vickers (2017)



<https://www.ccad.uiowa.edu/military/warfighter-simulation>

Characteristics of a Digital Twin:

- A virtual representation of a thing
 - Many different definitions
- Scalable
 - A twin can exist within a twin
- Flexible
 - Simulation and emulation
- Purposeful
 - Context dependent adaptations

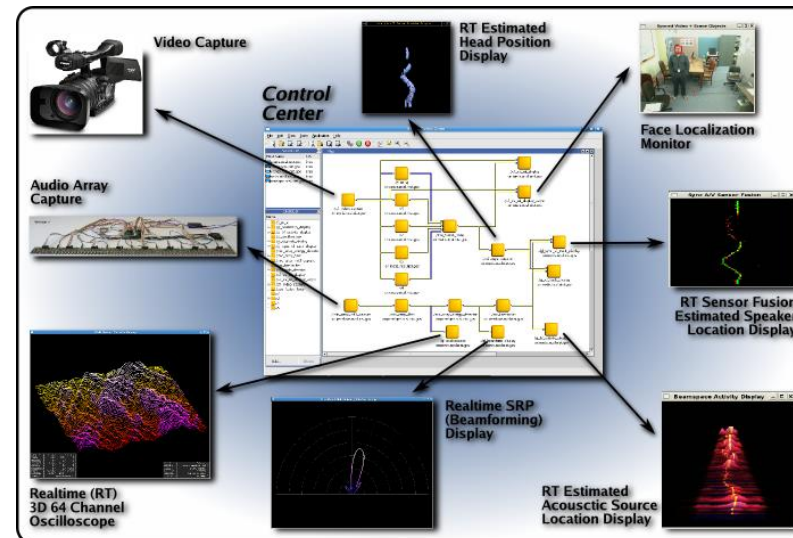

<https://www.nist.gov/itl/iad/mig/nist-smart-space-project/nist-smart-space-project-data-flow/nist-data-flow-system>



Leveraging the Digital Twin in Manufacturing **NIST**

With the increasing significance of data in manufacturing, the Digital Twin has become an important concept:

- Implications due to perspective/connotation;
- Couple to a physical counterpart;
- Often spatial and temporal components

The digital twin approach can be used to provide a basis on which detailed analyses can be performed

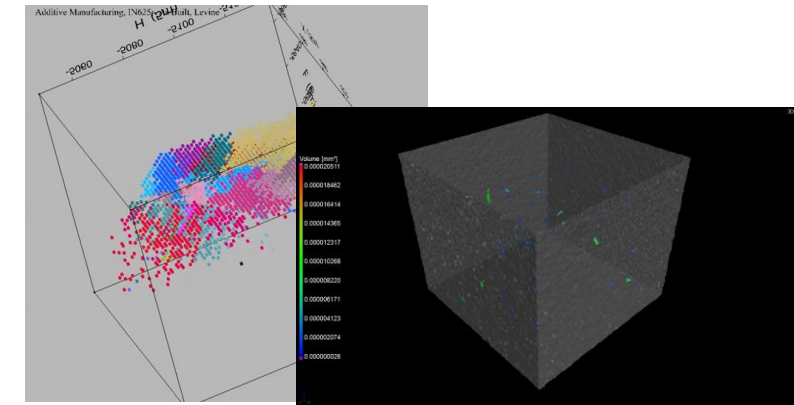
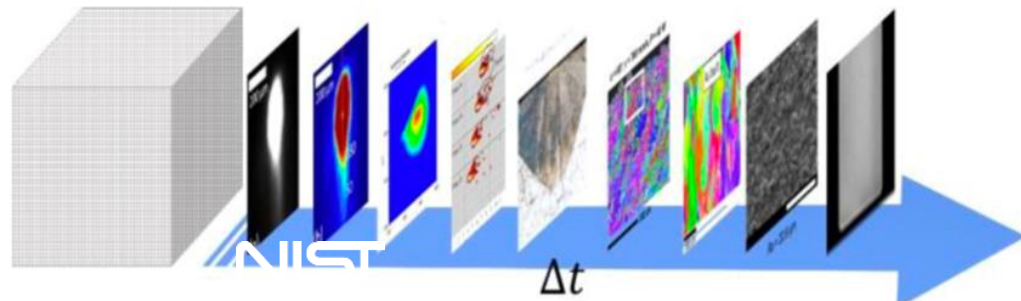

Obtaining Micro-scale Residual Stresses Using Synchrotron X-Rays

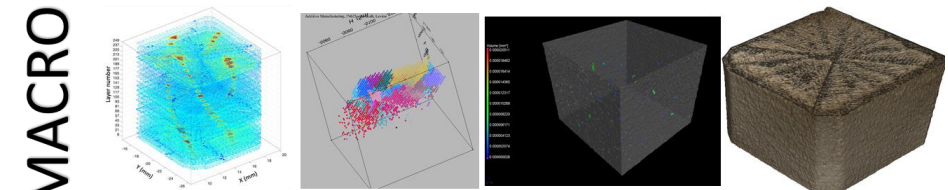
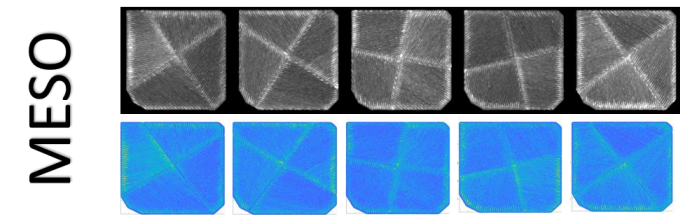
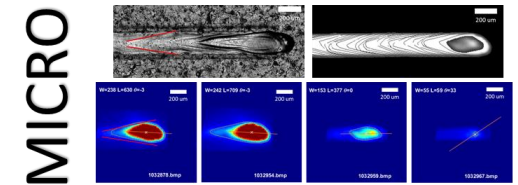

Today's Capabilities are Underpinned by a Digital Transformation

Industry 4.0 or Smart Manufacturing

- Often characterized by increased connectivity, automation, productivity and quality

The digital transformation has enabled:

- Increased trust in measured observations
 - Enormous amounts of data now being generated
 - Real world iterative approaches made possible by immediate empirical observations
- Increased production capabilities and capacities
 - Advancements in hardware and software
- Increased collaboration
 - Increased cross pollination in research activities
 - Increased cross pollination in standards communities

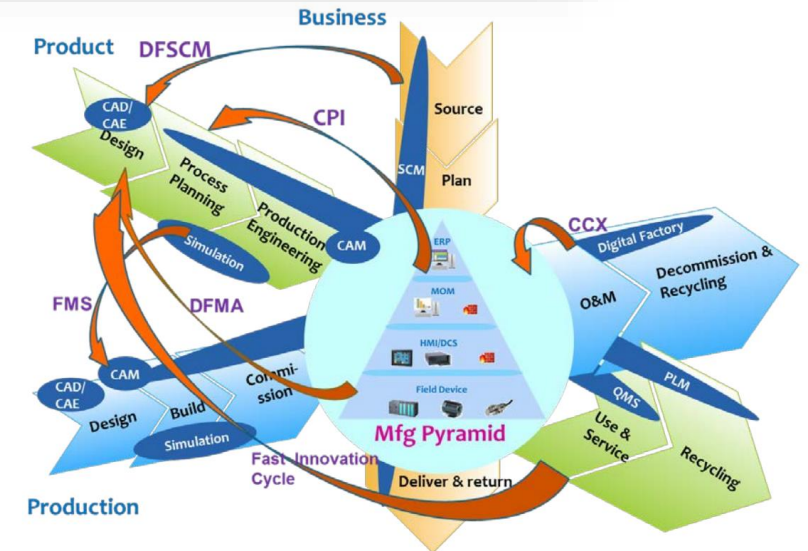

Smart Manufacturing Ecosystem: NIST

Enabling a Robust Supply Chain



Parts in Production with AM

Many companies are successfully using AM to create parts used across different industries!

GE Advanced turbo prop (ATP) -35 percent additive content and a huge parts-count reduction—from 855 subtractive-manufactured parts to just 12 additive-manufactured parts.



Unmanned undersea vehicle housing



GE T25 sensor



Safran combustor swirler and fuel injector nozzle

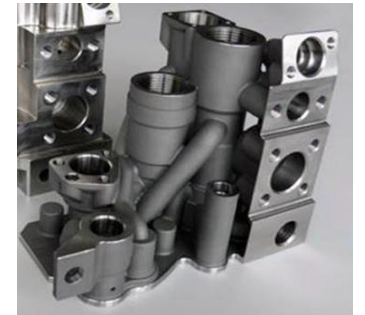

Airbus hydraulic manifold

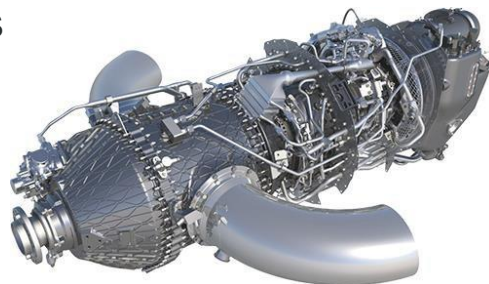

Baltic Orthoservice implant



Mercedes Benz thermostat cover



VW water connectors

Integration of AM into Supply Chain

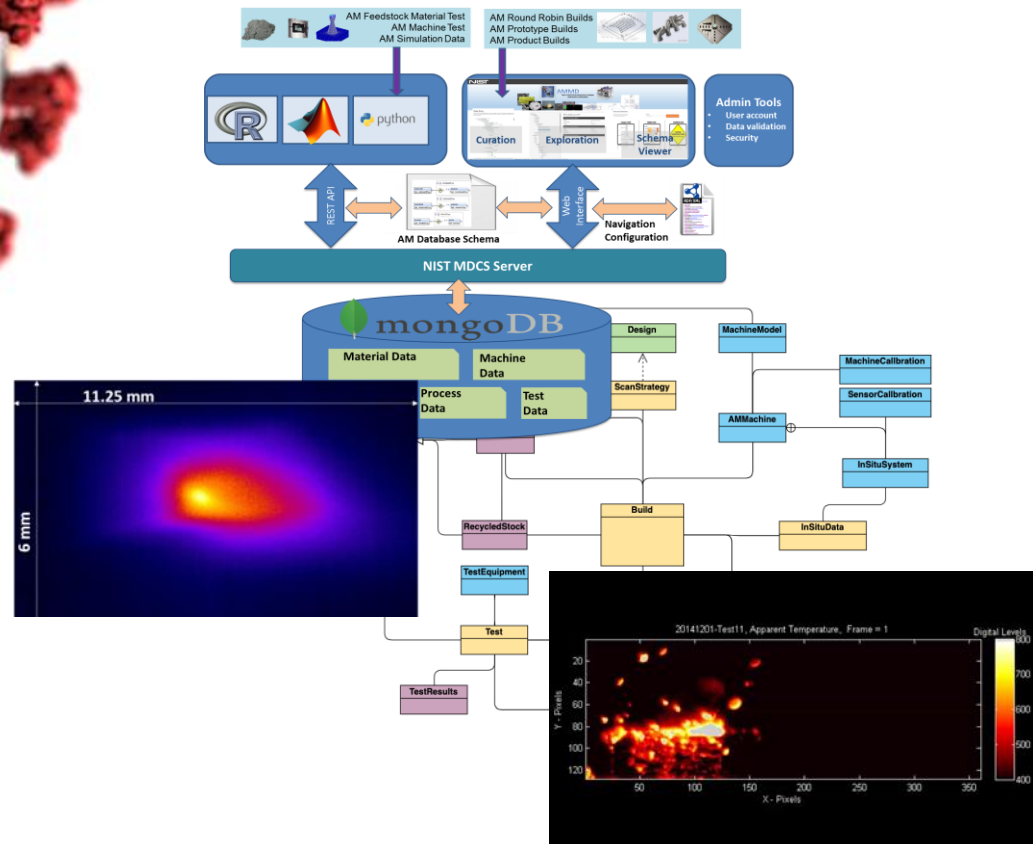
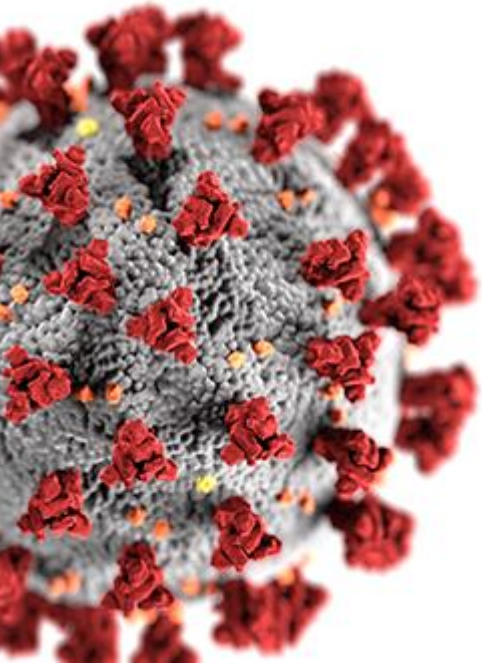

Established Role of AM in the national supply chain

- AM is a real alternative in supply chain agility
- Adjustments made for acceptance of parts
- Still lessons to learn
 - Concerns remain with quality control
 - Not accepted to the level of “traditionally manufactured” parts

In Situ and Ex Situ Non-Destructive measurements are increasingly used to for evaluation

- Contribute to creation of a “Digital Twin”

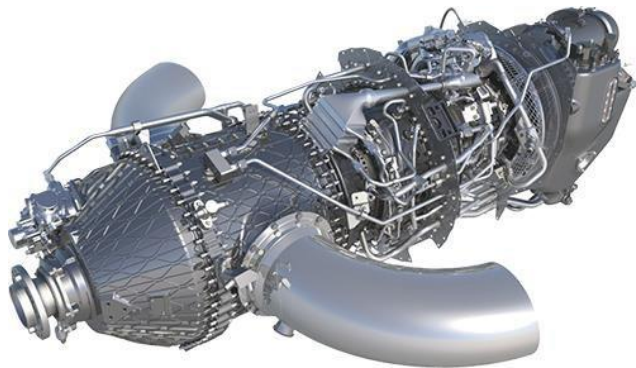

- With current AM production
 - Supply chains are vertical
 - Dedicated AM resources with well understood processes
- Even within organizations
 - Continuous engagement between design and manufacture
 - Process often “locked down” once suitable parameters are reached

What can be done to help make these supply chains more horizontal and/or better integrated?

A LOT of Our Ongoing Work Falls in Purview of Digitally-focused Standards and Robust Supply Chains

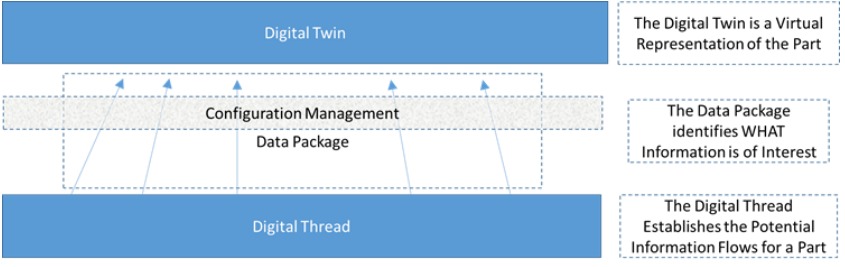
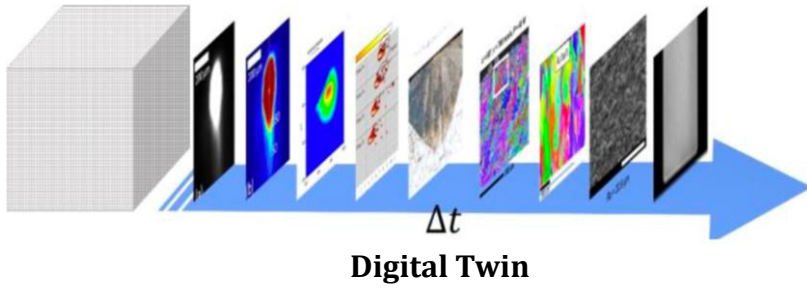

Additive Manufacturing—Data - Data Packages for AM Parts

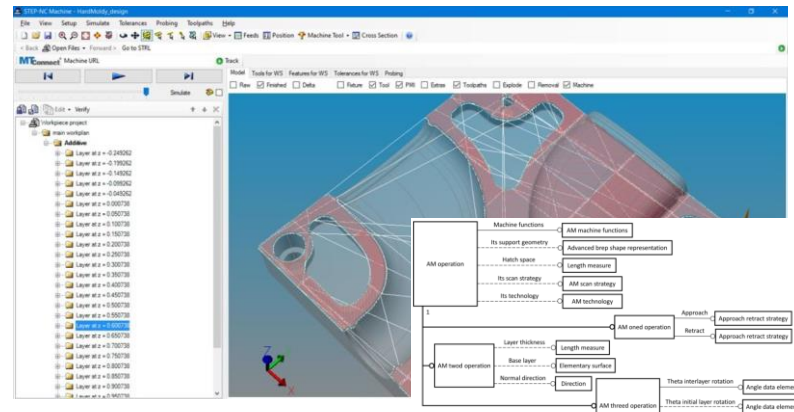

STEP-NC to AMMT

Diverse geometric representations in the workflow

How do we validate the part as it moves through different phases?

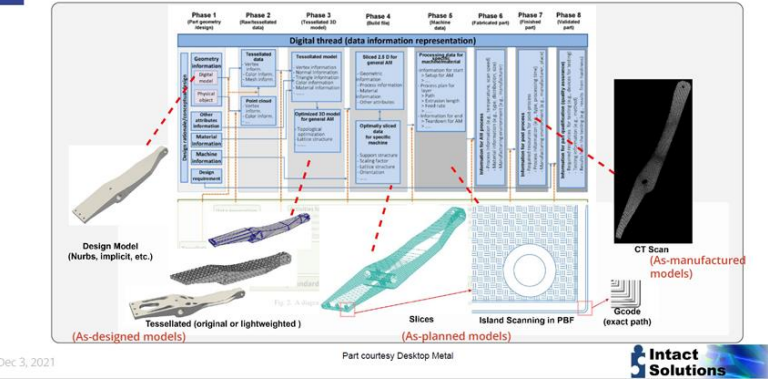

amBuild

- amProcesses
- feedstock
- generalInfo
- buildFile
- materialName
- partTests
- LWL_Layer1
- MPM_Layer1

Name	Type	Array Size	Value[50]...
buildID	String, length = 30, padding = H5T_STR_NULLPAD, cset = H5T_CSET_ASCII	Scalar	3dScanStrat
buildServiceProvider	String, length = 4, padding = H5T_STR_NULLPAD, cset = H5T_CSET_ASCII	Scalar	NIST
customerName	String, length = 188, padding = H5T_STR_NULLPAD, cset = H5T_CSET_ASCII	Scalar	MSAM
designID	String, length = 34, padding = H5T_STR_NULLPAD, cset = H5T_CSET_ASCII	Scalar	This build is 3dScanStrat
finishTime	String, length = 19, padding = H5T_STR_NULLPAD, cset = H5T_CSET_ASCII	Scalar	2018-07-08T
location	String, length = 12, padding = H5T_STR_NULLPAD, cset = H5T_CSET_ASCII	Scalar	Galthersburk
machineModel	String, length = 4, padding = H5T_STR_NULLPAD, cset = H5T_CSET_ASCII	Scalar	AMMT
machineSerialNumber	String, length = 3, padding = H5T_STR_NULLPAD, cset = H5T_CSET_ASCII	Scalar	001
machineVendor	String, length = 4, padding = H5T_STR_NULLPAD, cset = H5T_CSET_ASCII	Scalar	NIST
operators	String, length = 2, padding = H5T_STR_NULLPAD, cset = H5T_CSET_ASCII	Scalar	HY
startTime	String, length = 19, padding = H5T_STR_NULLPAD, cset = H5T_CSET_ASCII	Scalar	2018-07-08T
vendorMaterialID	String, length = 9, padding = H5T_STR_NULLPAD, cset = H5T_CSET_ASCII	Scalar	9011-0022

AM Data in HDF5

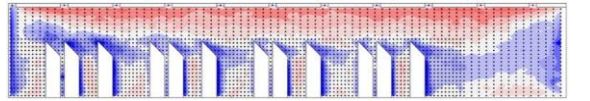

AM Bench

Material Property Analysis

- **Developing Data-based Standards**

Updates on Current Standards Involvement

Recently Released

- ASTM F3490-21 Standard Practice for Additive Manufacturing — General Principles — Overview of Data Pedigree
- ASME Y14.46- Product Definition for Additive Manufacturing

Recently Balloted

- ASTM WK73978 Standard Practice for Additive Manufacturing- General Principles- Data Registration

Recently Updated

- ASME B46.1-2019 Surface Texture
- ISO 21920-1:2021 - Geometrical product specifications (GPS)

Active Development

- ASTM F42 WK66682 “New Guide for Evaluating Post-processing and Characterization Techniques for AM Part Surfaces”
- ISO TC 261 JG 73: PWI 52951 Additive Manufacturing—Data – Data Packages for AM Parts
- ISO TC 184 WG 15 : STEP-NC AP-238 E4
- ISO TC 184 WG 15 ISO 23247 Digital Twin Framework for Manufacturing
- ASTM WK73289 Guide for In-Process Monitoring of Metal Additively Manufactured Aerospace Parts
- ASTM F42 WK76038 New Test Method for Additive Manufacturing of Metals

Leveraging Digital Twins in AM

- Outlining data and format representation requirements -I
- Including HDF5
- Extending work with STEP NC
- New standardization opportunities for validation
- Qualification through data and part analysis

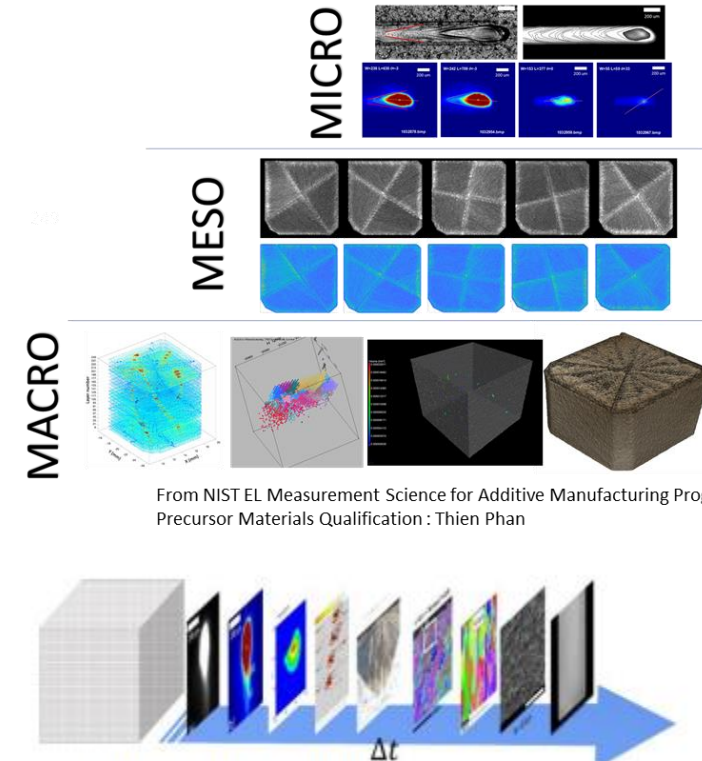
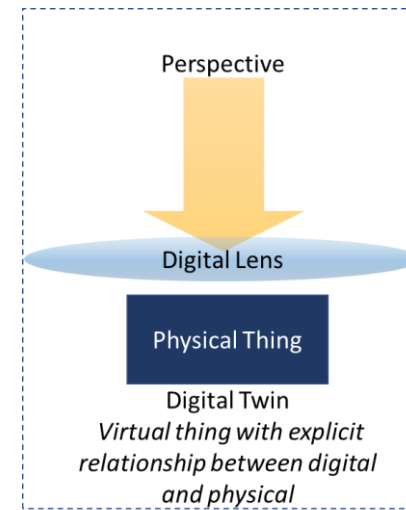
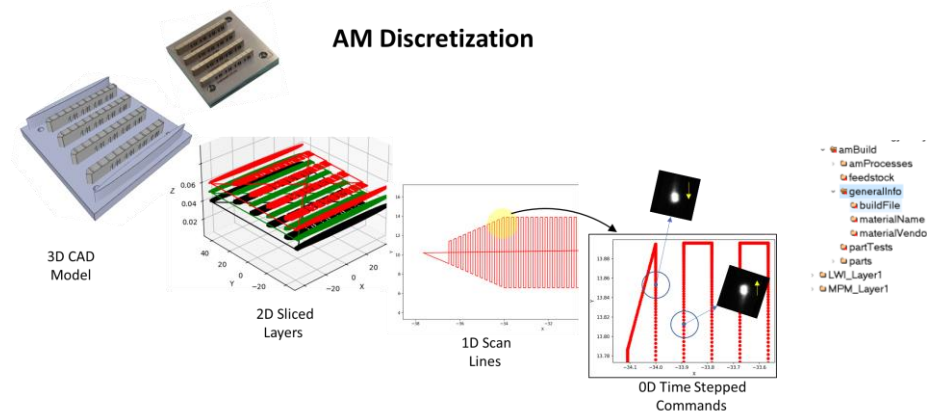

Figure 5. Data registration across time t .



Attribute Creation Order: Creation Order NOT Tracked			
Name	Type	Array Size	Value[50]...
buildID	String, length = 30, padding = H5T_STR_NULLPAD, cset = H5T_CSET_ASCII	Scalar	3dScanStrat
buildServiceProvider	String, length = 4, padding = H5T_STR_NULLPAD, cset = H5T_CSET_ASCII	Scalar	NIST
customerName	String, length = 4, padding = H5T_STR_NULLPAD, cset = H5T_CSET_ASCII	Scalar	MSAM
description	String, length = 188, padding = H5T_STR_NULLPAD, cset = H5T_CSET_ASCII	Scalar	This build is
designID	String, length = 34, padding = H5T_STR_NULLPAD, cset = H5T_CSET_ASCII	Scalar	3dScanStrat
finishTime	String, length = 19, padding = H5T_STR_NULLPAD, cset = H5T_CSET_ASCII	Scalar	2018-07-08T
location	String, length = 12, padding = H5T_STR_NULLPAD, cset = H5T_CSET_ASCII	Scalar	Gaithersburg
machineModel	String, length = 4, padding = H5T_STR_NULLPAD, cset = H5T_CSET_ASCII	Scalar	AMMT
machineSerialNumber	String, length = 3, padding = H5T_STR_NULLPAD, cset = H5T_CSET_ASCII	Scalar	001
machineVendor	String, length = 4, padding = H5T_STR_NULLPAD, cset = H5T_CSET_ASCII	Scalar	NIST
operators	String, length = 2, padding = H5T_STR_NULLPAD, cset = H5T_CSET_ASCII	Scalar	HY
startTime	String, length = 19, padding = H5T_STR_NULLPAD, cset = H5T_CSET_ASCII	Scalar	2018-07-08T
vendorMaterialID	String, length = 9, padding = H5T_STR_NULLPAD, cset = H5T_CSET_ASCII	Scalar	9011-0022

Data Registration

- ISO/ASTM DIS 52953 Registration of geometric data acquired from process-monitoring and for quality control
 - To go to DIS ballot this month

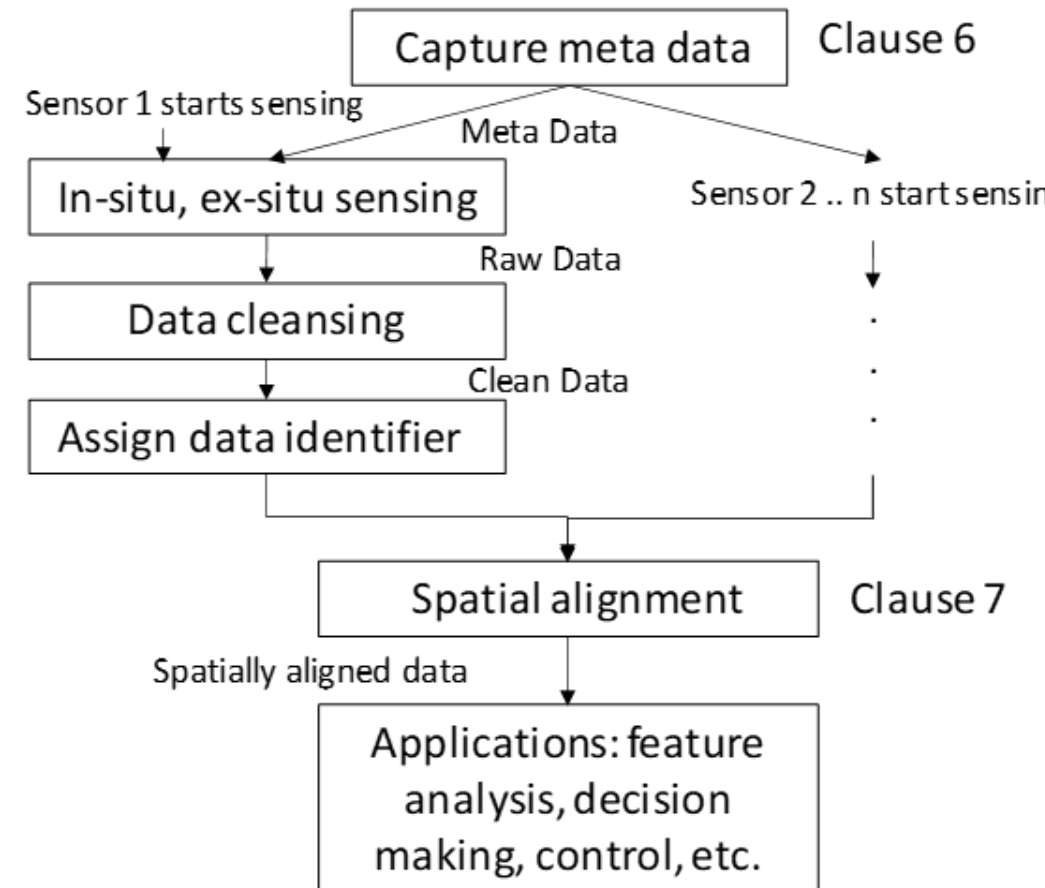
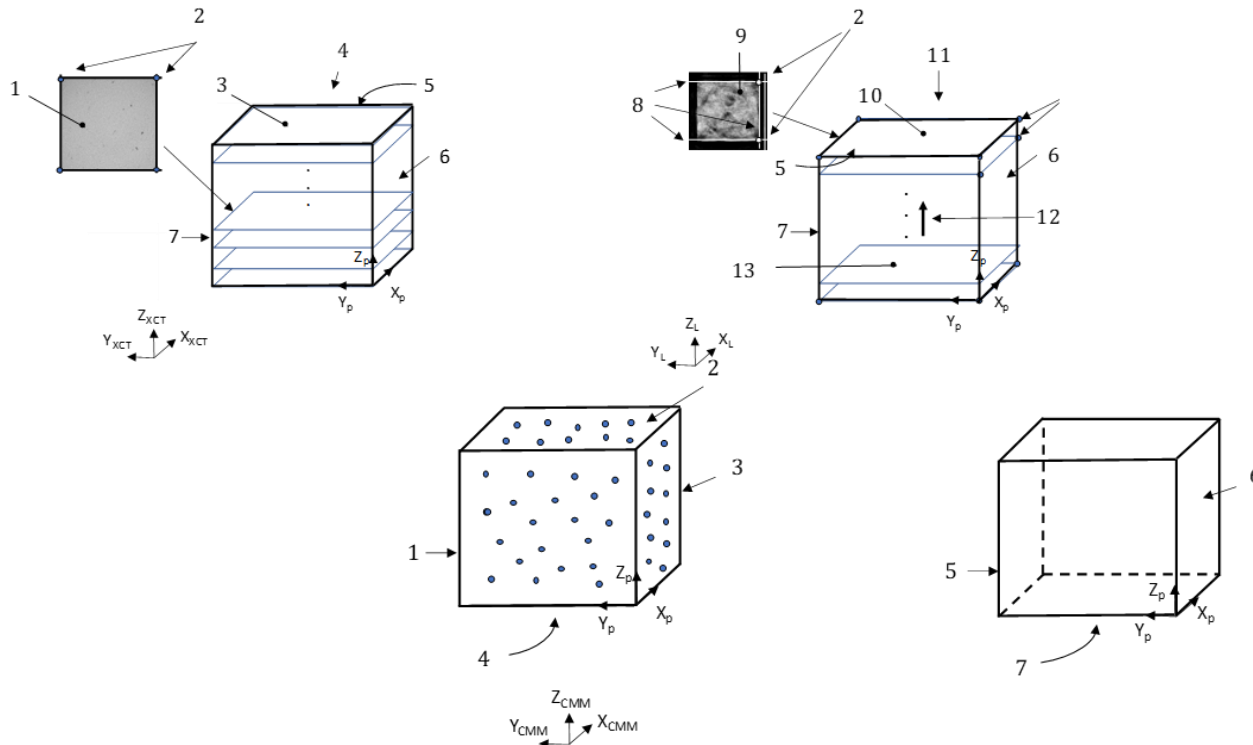

Supply Chain Integration through Data Packages

ISO TC 261 JG73 (Product Design Definition and AM Data Management)

- ISO PWI 52951 Additive Manufacturing—Data—Data Packages for AM Parts

	Acquisition	Manufacture in House	Verification Only
Process Maturity	Expeditionary	Developmental	Production
Part Maturity			
Prototype	General (G1, G2, G4,1) Part (P2, P3,1, P4,3) Material (M1) Inspection (I2,1)		
New Part			
Existing Part			

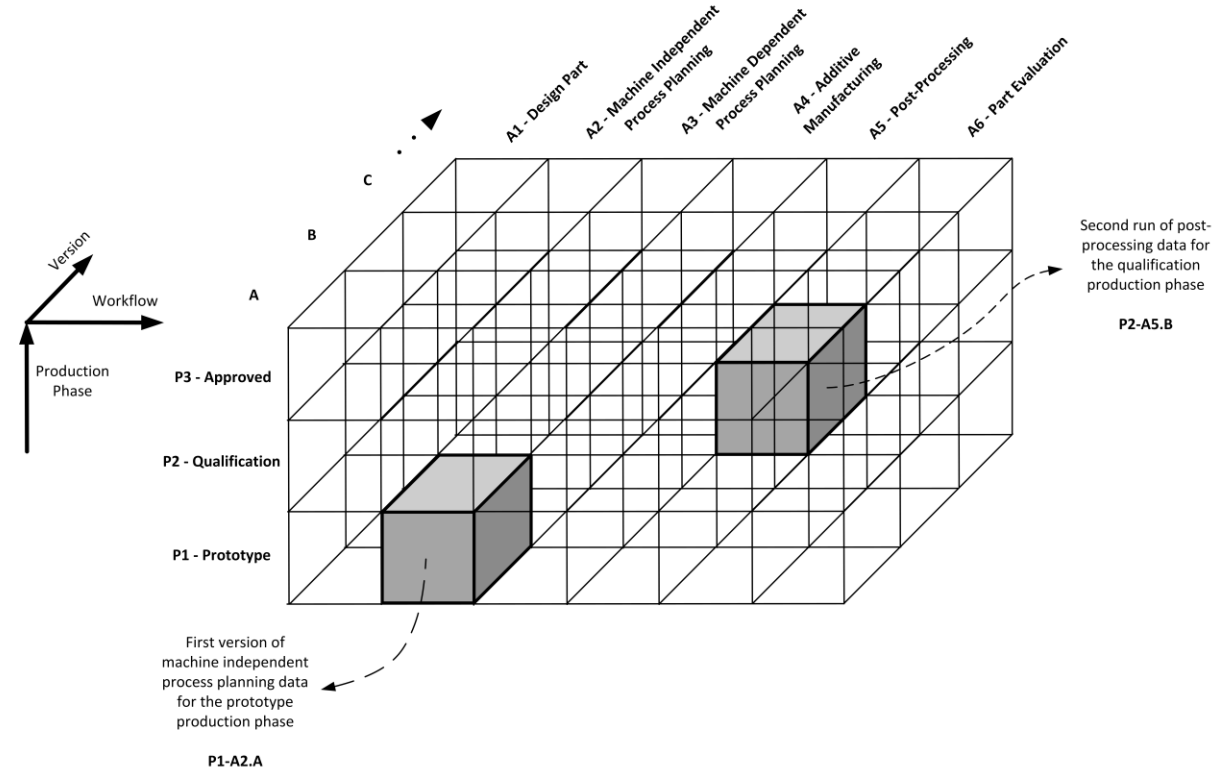
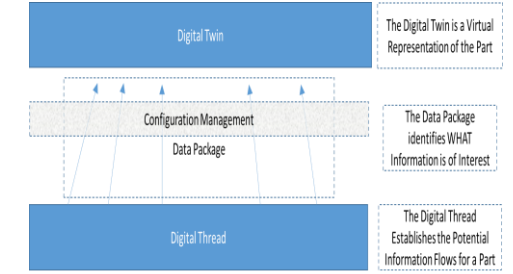

	High Capability	More Capability	Medium Capability	Less Capability	Low Capability
High Critical	Medium Control	Medium to High Control	High Control	Not Recommended	Not Recommended
More Critical	Medium to Low Control	Medium Control	Medium to High Control	High Control	Not Recommended
Medium	Low Control	Medium to Low Control	Medium Control	Medium to High Control	High Control
Less Critical	Low Control	Low Control	Medium to Low Control	Medium Control	Medium to High Control
Low Critical	Low Control	Low Control	Low Control	Medium to Low Control	Medium Control

Distributed Data Sharing through Common Interpretations



F3490-21 Standard Practice for Additive Manufacturing — General Principles — Overview of Data Pedigree

“Common Data Dictionary”

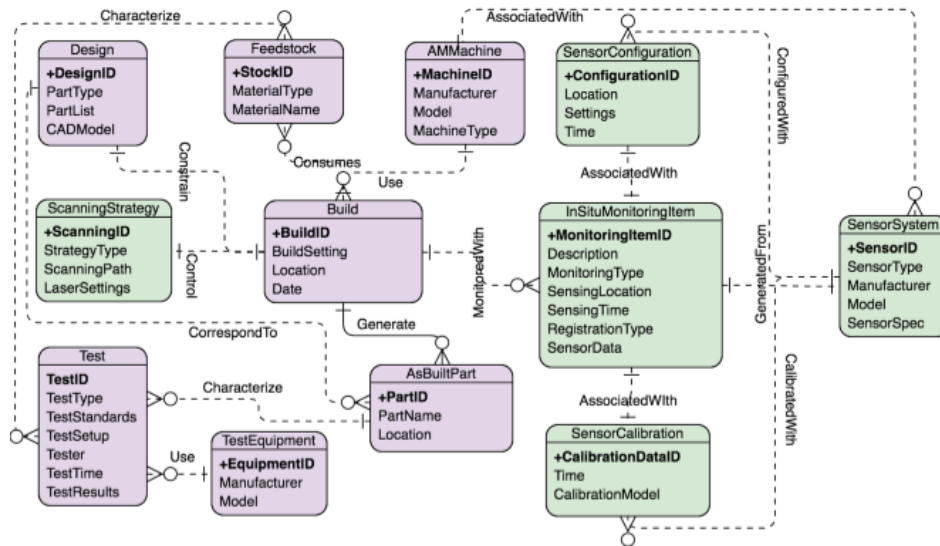

The screenshot shows the ASTM International website for the standard F3490-21. The page title is "Standard Practice for Additive Manufacturing — General Principles — Overview of Data Pedigree". The page includes a search bar, navigation links, and a table of contents. The main content area is titled "A new 'dictionary' for additive manufacturing data" and includes a technical contact, organizations, and a sign-up for updates from NIST.

ASTM F3490-21
Standard Practice for Additive Manufacturing — General Principles — Overview of Data Pedigree

1. Scope

1.1 The scope of this document outlines the interpret legacy AM data is stored in different databases or dat own data dictionary. A common data dictionary allows federated, and analyzed to improve both the understa parts.

1.2 A common data dictionary facilitates the Interopere (1) identifying the general AM data pedigree elements (2) defining those salient terms with indisputable seme provide a first subset of the common data dictionary b

agree to the storing of cookies on your device to enhance site navigation, analyze site usage,

Technical Contact: Yan Lu, yan.lu@nist.gov, (301) 975-6226

Organizations: Engineering Laboratory, Systems Integration Division

Sign up for updates from NIST: Enter Email Address, Sign up

Manufacturing, Additive manufacturing and Systems Integration

Created: May 20, 2022

Model Based Definition



ASME Y14.46- Product Definition for Additive Manufacturing

The only standard that extends to capturing relevant additive manufacturing detail from design, manufacturing and quality engineering is **Y14.46**. Along with that, this Standard also covers definitions of terms & features unique to AM technologies with recommendations for their uniform specification.

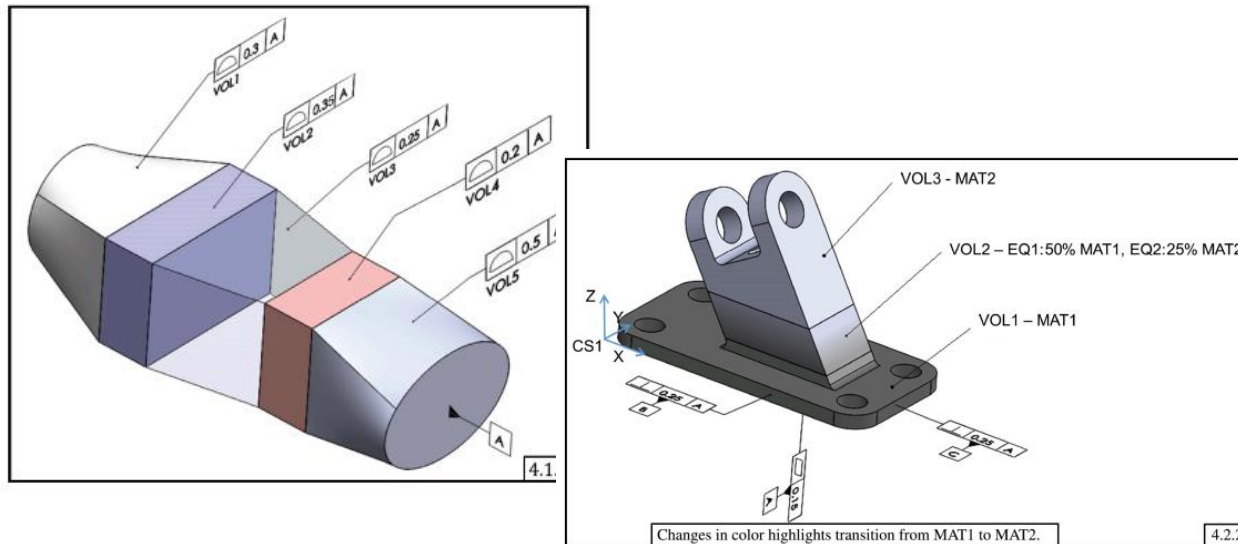

ASME Y14.46-2022

Product Definition for Additive Manufacturing

Engineering Product Definition and Related Documentation Practices

AN AMERICAN NATIONAL STANDARD

The American Society of Mechanical Engineers

METAL AM

ASME and NIST update AM design language standard

June 10, 2022

Download the latest issue of Metal AM magazine

Ready for the Future of Additive Manufacturing

DE247 Digital Engineering

NVIDIA RTX A5500 THE POWER TO CREATE

Updated Standard Provides 3D Printing Design Guidance

The guidance could help engineers from a broad array of industries communicate to manufacturers, product inspectors and others more effectively.

By DE Editors
June 10, 2022

The American Society of Mechanical Engineers (ASME) published an updated standard—based in large part on research by the National Institute of Standards and Technology (NIST)—that includes language specifically for 3D printing. ASME's standard, titled Y14.46 Product Definition for Additive Manufacturing, identifies important features for 3D printing and outlines how they should be documented.

The guidance could help engineers from a broad array of industries communicate to manufacturers, product inspectors and others more effectively. Its adoption could clear a roadblock to the application of 3D printing at a larger scale.

"The industry is in a digital transformation right now, moving away from physical 2D drawings, and additive manufacturing is one of the catalysts since it requires digital 3D models," says Fredric Constantino, an ASME project engineering adviser. "And if you're working on one of those models, this standard will guide you in making it understandable to both 3D printers and other people."

Neutral Part and Process Representations

STEP-NC effort to incorporate AM process information as neutral STEP representation

-Proposed Edits for AP238 E4

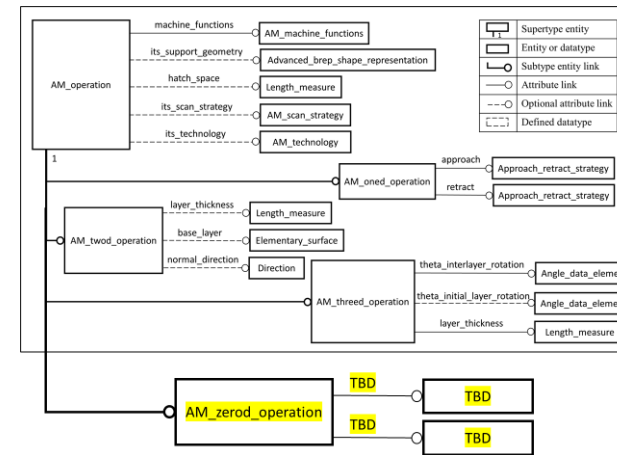

AM Discretization

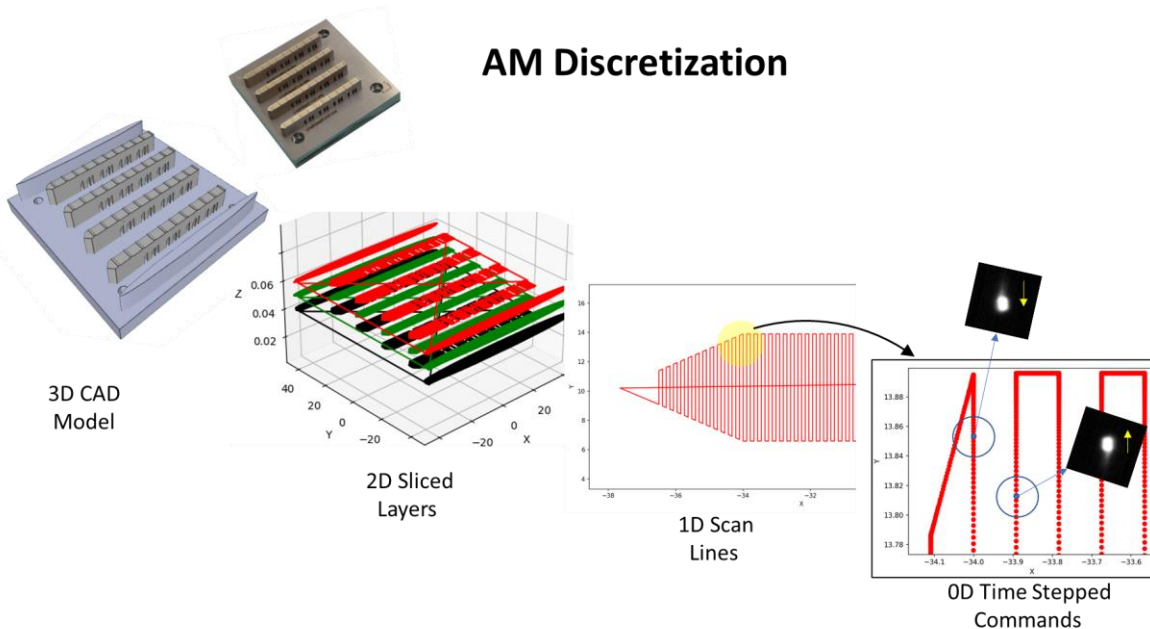

3D
CAD model
(X,Y,Z) Coordinates

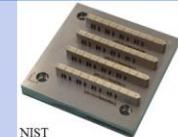
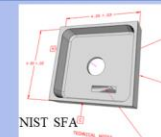

2D
Sliced Layers,
Scan Strategies



1D
Scan Paths,
Contour

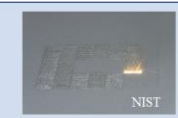

0D
Time Stepped
Digital Command

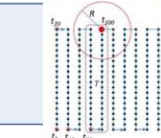

Recent Data Standards Developments



Creation of ASTM F42.08 on Data Standards for AM (2020)

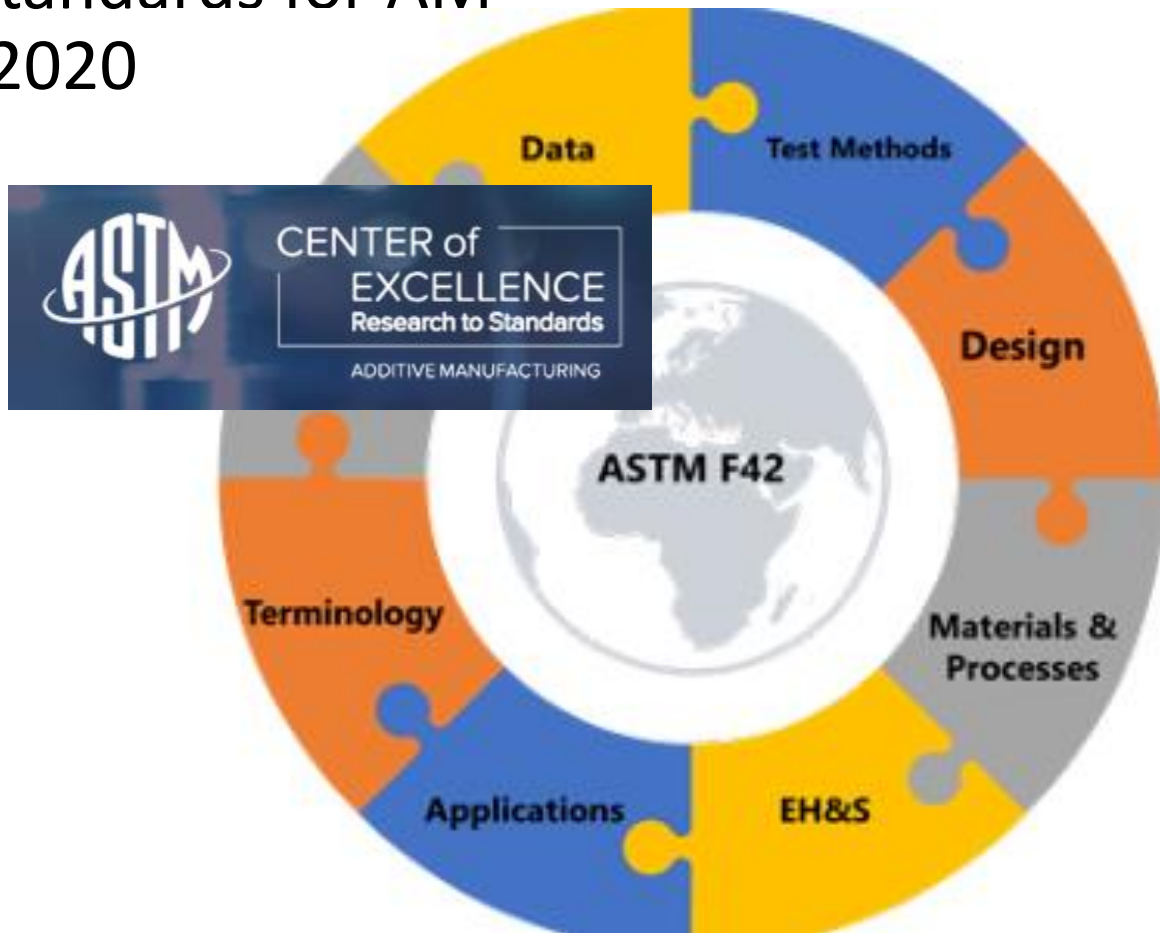

New AMSC Chapter (Additive Manufacturing Standards Collaborative) on Data (2023)

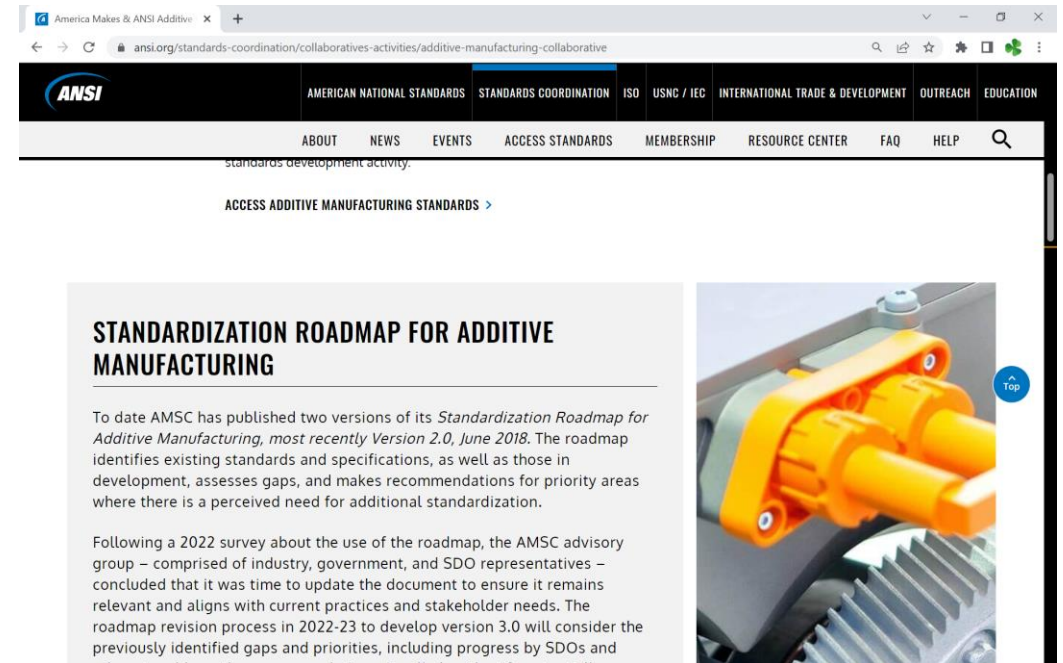

Recent and Upcoming Efforts



Using Additive Manufacturing to Improve Supply Chain Resilience and Bolster Small and Mid-Size Firms

On [May 6th](#), President Biden joined five leading U.S. manufacturers to celebrate the launch of Additive Manufacturing Forward (AM Forward). [AM Forward](#) is a voluntary compact among large manufacturers to help their smaller U.S.-based suppliers increase their use of additive manufacturing, otherwise known as 3D printing. The Biden Administration will support this effort with a variety of current and proposed Federal initiatives. These public and private efforts have potential benefits up and down supply chains in many industries: enhancing small firms' ability to make and sell higher-performing parts,



Empowering Small and Medium Size Enterprises Through Effective Additive Manufacturing Data Management



SAVE the DATE:

The workshop will explore how best to empower the productive working relationship of small and medium size Enterprises (SMEs) with top tier manufacturers through effective additive manufacturing (AM) data management. NIST will host the event in partnership with the National Manufacturing Innovative Institute for additive manufacturing, America Makes and the Regional Additive Manufacturing Partnership of Maryland (RAMPM). The goal is to examine the AM data management "Pain Points" associated with SME interactions with large system integrators



Credit: Stock Photo ID: 2167716015

[Read the Code of Conduct for NIST Conferences.](#)

WORKSHOP

June 6 - 8, 2023

NCCoE
9700 Great Seneca Highway
Rockville, MD 20850

Registration will open soon!

REGISTRATION CONTACT

- FY23 a transition year for MSAM Program
 - Continue to move forward, but with an open mind
 - Planning for new 5-year program focused on AM
 - Incorporate feedback from upcoming Additive Manufacturing Standards Collaborative Roadmap refresh
 - Potential for measurement science road mapping workshops
 - Engagement with key stakeholders to identify emerging AM measurement science needs



Thank You

Paul Witherell, PhD
paul.witherell@nist.gov
National Institute of Standards
and Technology